

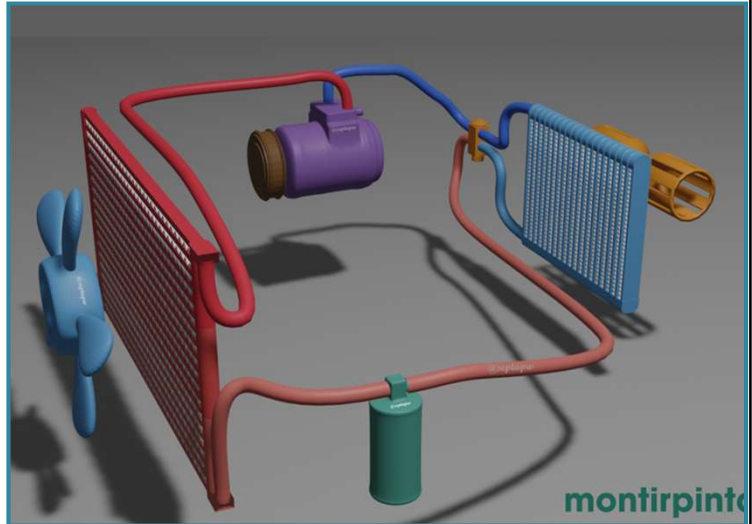

CAR AIR CONDITIONER

AUTO SERVICE



Auto Service Academy



TUJUAN

- Peserta memahami fungsi AC
- Peserta memahami prinsip kerja AC
- Peserta bisa melakukan perawatan AC
- Peserta bisa melakukan pekerjaan perbaikan AC mobil



Auto Service Academy



GAMBARAN UMUM A/C MOBIL

- Sistem A/C Mobil
- Komposisi A/C Mobil
- Tipe-tipe A/C Mobil

Auto Service Academy



FUNGSI AIR CONDITIONER



Auto Service Academy



KOMPOSISI AC MOBIL

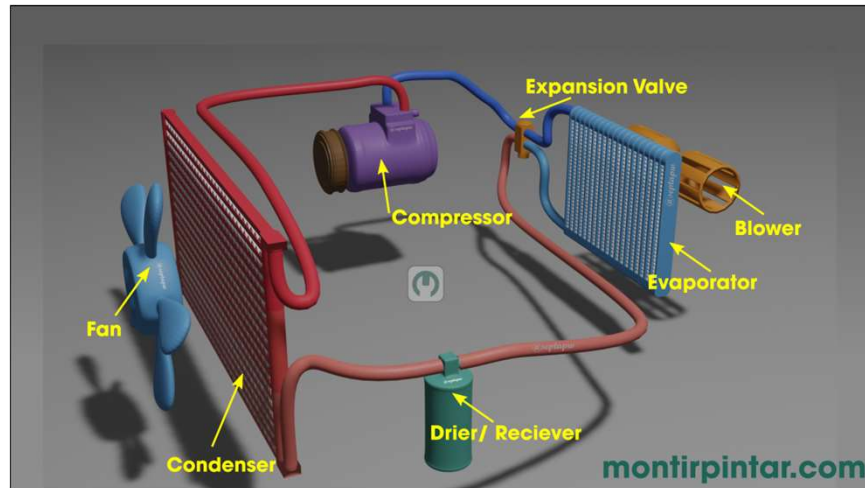

Auto Service Academy



KOMPOSISI AC & PANEL AC MOBIL

KOMPONEN A/C

Komponen A/C diruang penumpang seperti blower unit, cooling unit dan heater unit.

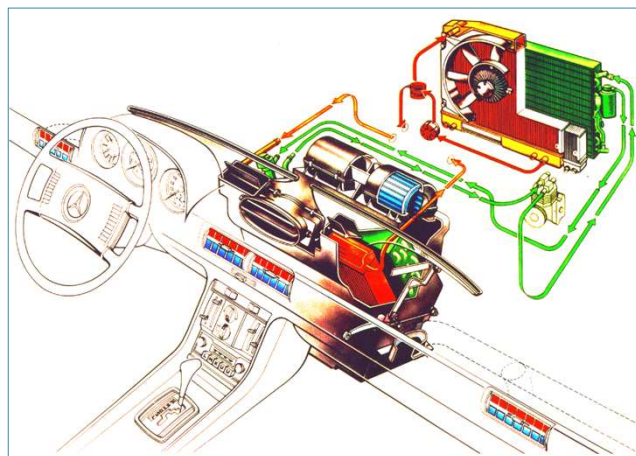

Auto Service Academy



CONTROL PANEL

CONTROL PANEL

Terdapat pada dash board bagian tengah disamping pengemudi untuk memudahkan pengoperasiannya.

Melalui kontrol panel dapat dilakukan pengaturan suhu, pengaturan udara masuk fresh / recycle, pengaturan kecepatan blower, mematikan dan menghidupkan compressor.

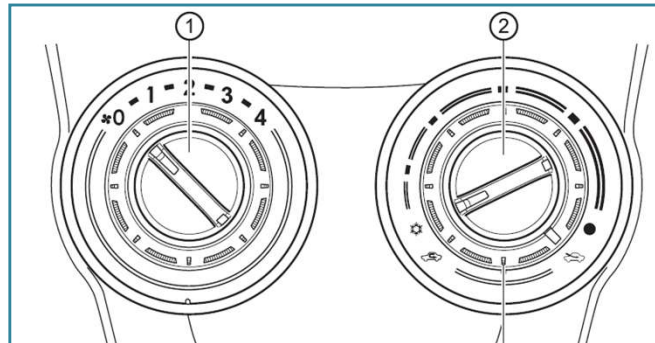

Auto Service Academy



TIPE-TIPE AC MOBIL



Auto Service Academy



KLASIFIKASI SESUAI LOKASI PEMASANGAN

A/C DEPAN

Cooling unit dipasang dibawah atau bagian dalam dash board dan berhubungan dengan heater unit. Blower unit menghirup udara dari saluran masuk fresh/recycle dan meniupkannya kembali. Umumnya udara dingin keluar melalui saluran keluar bagian tengah, sisi pengemudi dan penumpang. Udara panas biasanya keluar melalui saluran keluar pada kaki dan kaca

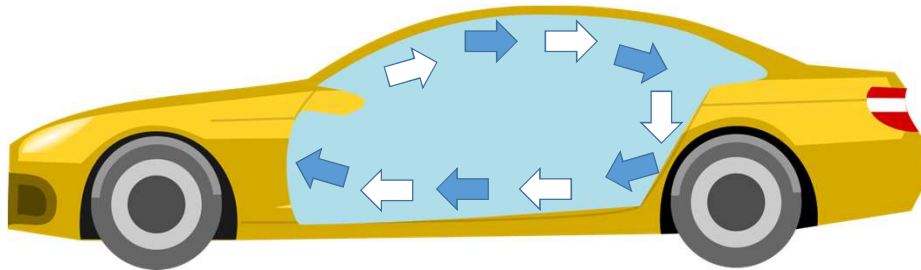

Auto Service Academy



KLASIFIKASI SESUAI LOKASI PEMASANGAN

A/C Belakang (Cooler)

Umumnya cooling unit dipasang pada kabin belakang atau diatas kabin bagian tengah mobil, dapat digunakan bersamaan dengan A/C depan. Cooling unit yang dipasang di kabin belakang biasanya tipe ini disebut dengan Dual A/C dan yang dipasang diatas kabin bagian tengah tipe ini biasanya disebut Dual A/C Tambahan.

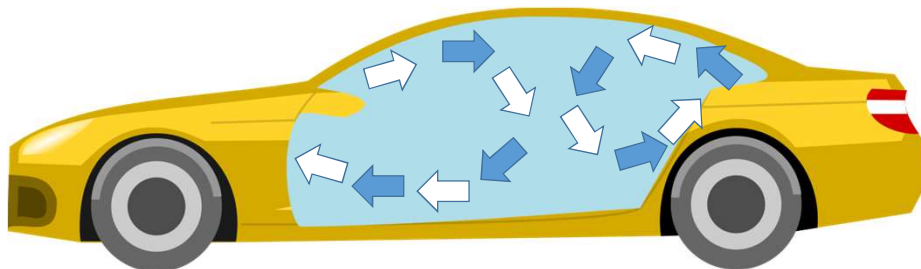

Auto Service Academy



KLASIFIKASI SESUAI LOKASI PEMASANGAN

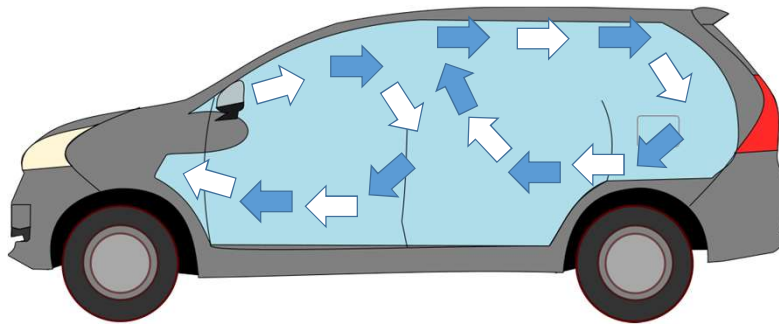

Auto Service Academy



KLASIFIKASI SESUAI SISTEM KONTROLNYA

MANUAL A/C

Pengaturan suhu ruangan dilakukan dengan menggeser tombol pada kontrol panel A/C, dimana ada beberapa step pengaturan seperti kecepatan blower, pengaturan udara masuk.



Auto Service Academy



KLASIFIKASI SESUAI SISTEM KONTROLNYA

AUTOMATIC A/C

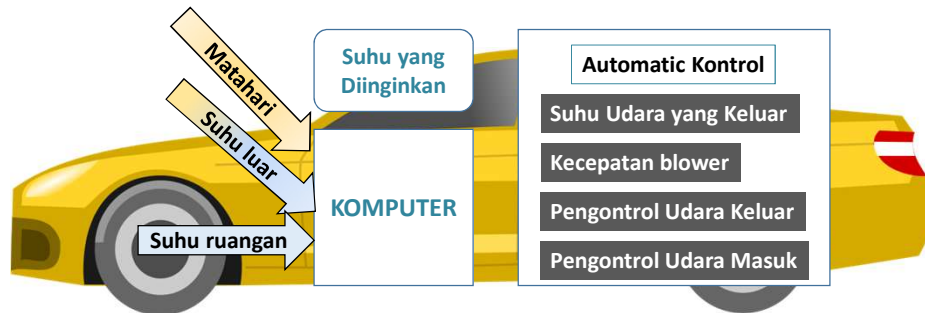

Auto Service Academy



DASAR-DASAR A/C MOBIL

- Dasar-dasar A/C Mobil
- Dasar-dasar pemanas A/C Mobil
- Sistem A/C Mobil

Auto Service Academy



PRINSIP DASAR AC MOBIL

Prinsip dasar A/C banyak terjadi pada kehidupan sehari-hari seperti menempelkan kapas yang beralkohol ke kulit atau saat menyiram tanaman di siang hari.



Auto Service Academy



PRINSIP DASAR AC MOBIL

- Alkohol atau air mendapat / mengambil panas dari sekitarnya sebab cairan membutuhkan panas saat menguap untuk berubah menjadi gas. Kejadian alam tersebut dimanfaatkan pada Prinsip Dasar A/C..

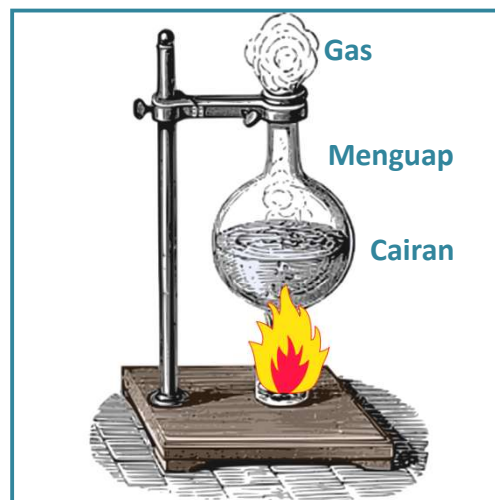

Auto Service Academy



PERUBAHAN WUJUD

- Fusi : Padat berubah cair
- Solidifikasi : Cair berubah padat
- Evaporasi : Cair menjadi gas (uap)**
- Kondensasi : Gas menjadi cair.**
- Sublimasi : Padat menjadi uap.
- Adhesi : Uap menjadi padat.

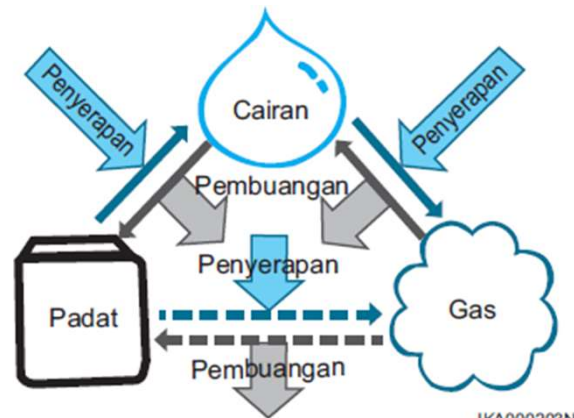

Auto Service Academy



REFRIGERANT

- Refrigerant HFC-134a [R134a] digunakan pada sistim A/C mobil karena hal sebagai berikut :
- Tidak merusak hose dari karet.
- Ramah lingkungan dan tidak merusak lapisan ozone.
- Panas latent-nya bagus dan mudah mencair.
- Tidak mudah terbakar atau meledak.
- Tidak beracun, tidak menyebabkan karatan dan tidak merusak makanan / pakaian.
- Mudah didapatkan.



Auto Service Academy



SIFAT REFRIGERANT

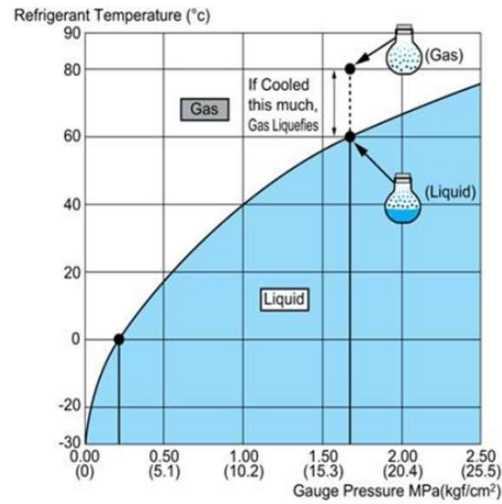

Auto Service Academy



KOMPONEN AC MOBIL

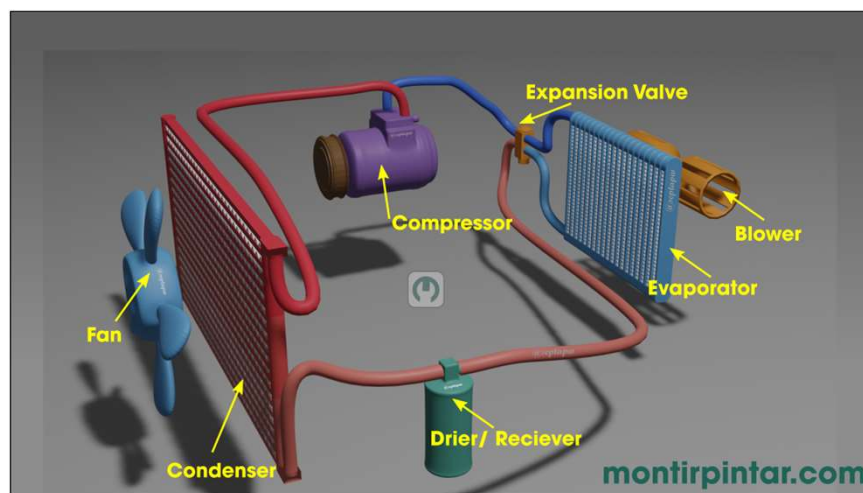

Auto Service Academy



SIRKULASI REFRIGERANT PADA AC MOBIL

Auto Service Academy



KOMPRESOR

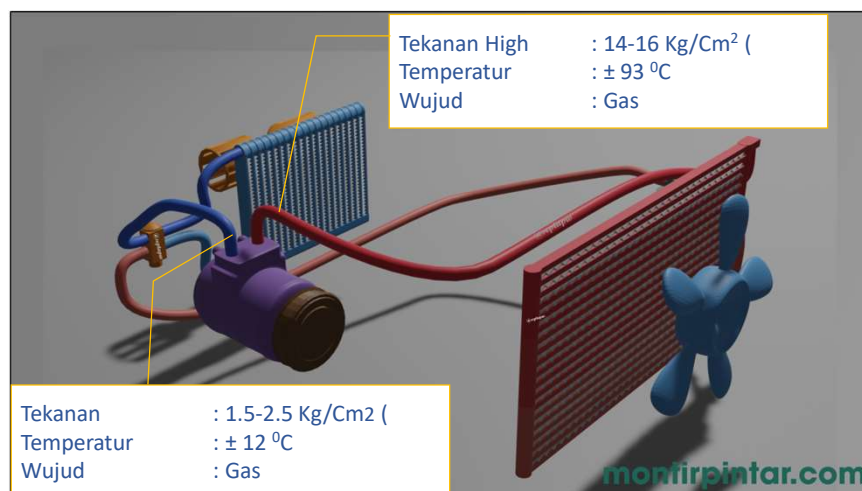

Auto Service Academy



TIPE-TIPE AC MOBIL

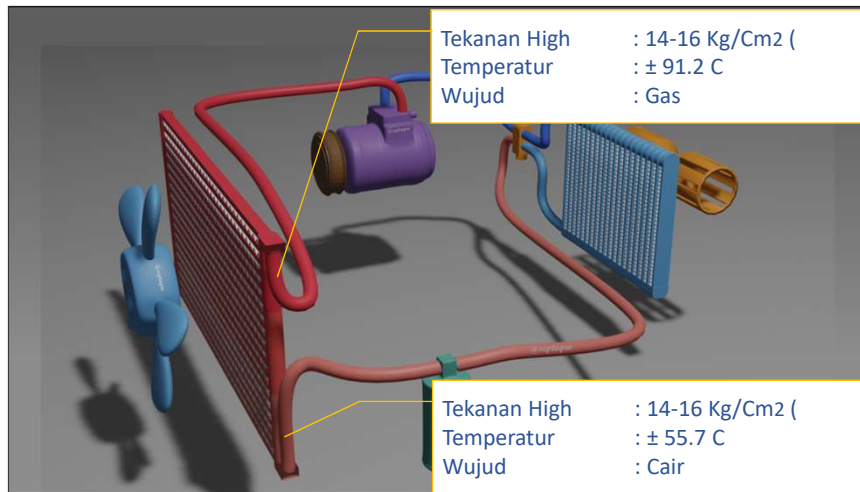

Auto Service Academy



TIPE-TIPE AC MOBIL

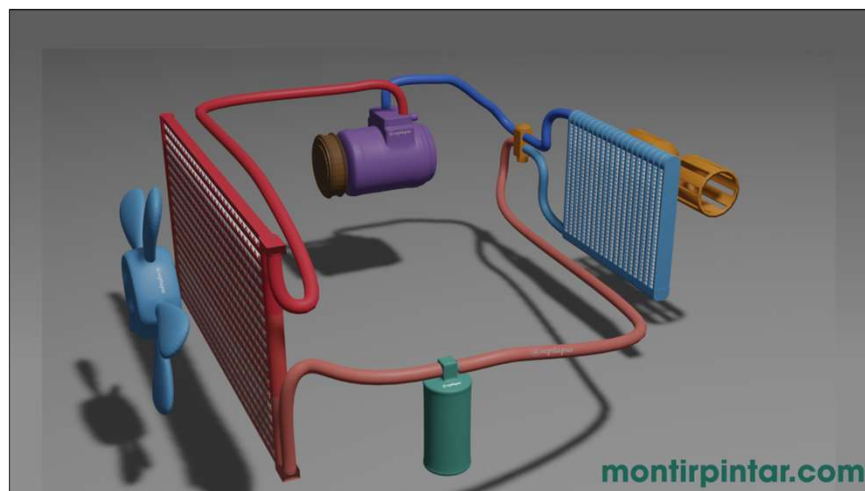

Auto Service Academy



TIPE-TIPE AC MOBIL

Tekanan High : 1.5-2.5 Kg/Cm2 (
Temperatur : ± 4.1 °C
Wujud : Kabut

Tekanan High : 14-16 Kg/Cm2 (
Temperatur : 55 °C
Wujud : Cair

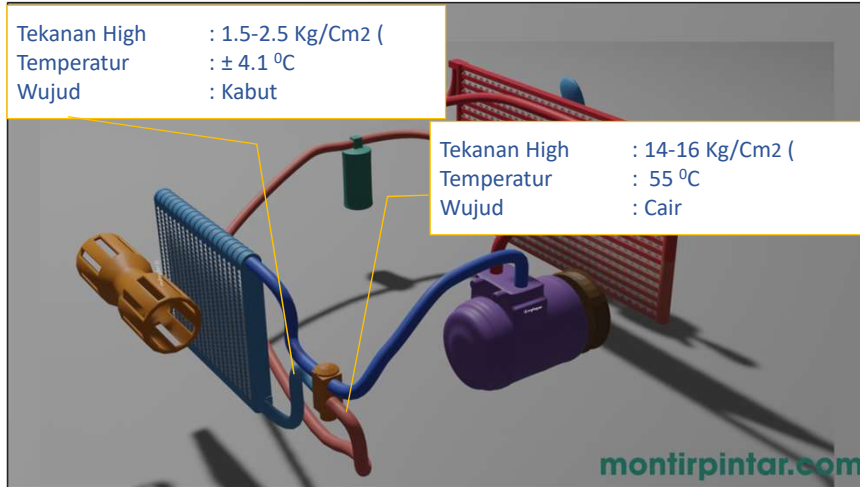

Auto Service Academy



TIPE-TIPE AC MOBIL

Tekanan Low : 1.5-2.5 Kg/Cm2 (
Temperatur : ± 6 °C
Wujud : Gas

Tekanan Low : 1.5-2.5 Kg/Cm2 (
Temperatur : ± 4 °C
Wujud : Kabut

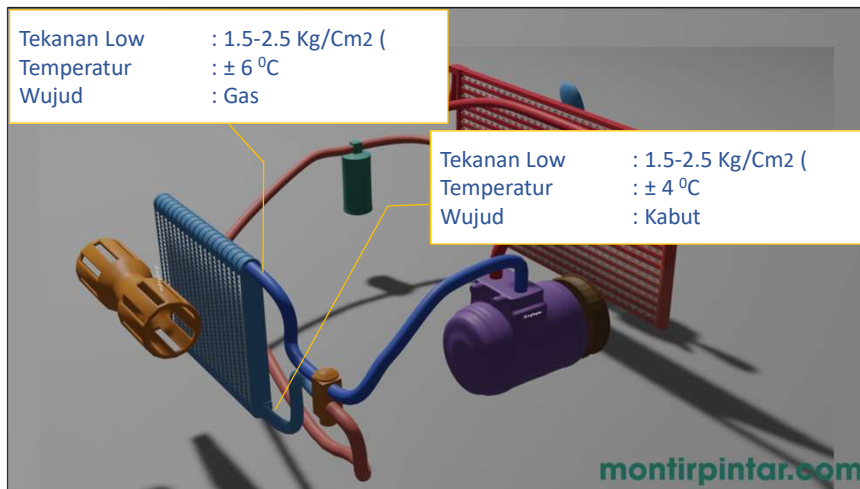

Auto Service Academy



HEATER

Pada A/C mobil, panas untuk ruang penumpang biasanya diambil dari pertukaran panas antara air pendinginan mesin / air radiator dan udara dingin dari ruang penumpang. Water pump mengalirkan air pendinginan mesin ke heater core dan katup air mengontrol jumlah air yang dialirkan

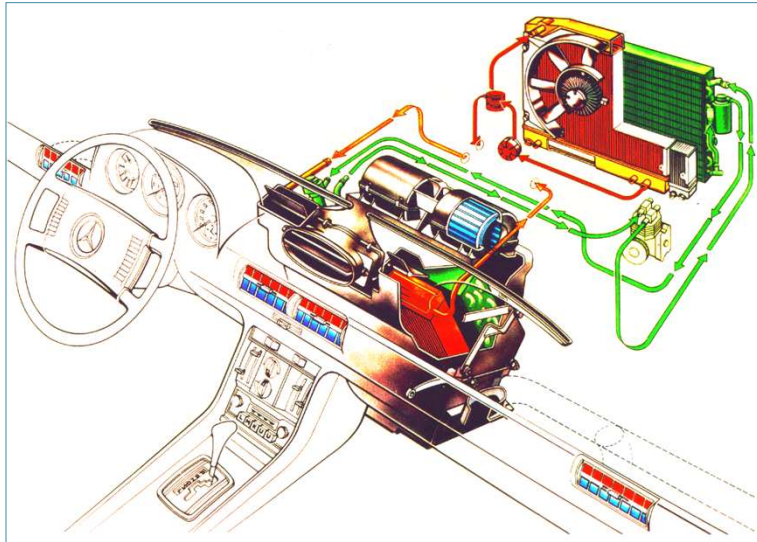

Auto Service Academy



KLASIFIKASI HEATER

TIPE AIR MIX

Tipe ini mempertahankan suhu dengan mengontrol perbandingan udara panas dan udara dingin melalui dumper air mix.

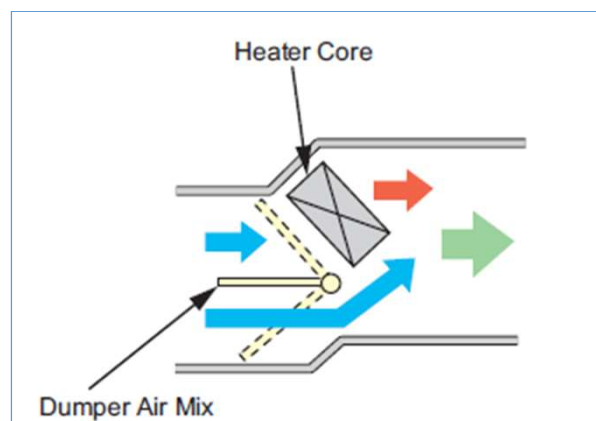

Auto Service Academy



KLASIFIKASI HEATER

Tipe Flow Control

Katup air mengontrol dan mengatur jumlah air panas yang masuk ke heater core dan sekaligus mengatur suhu heater core.

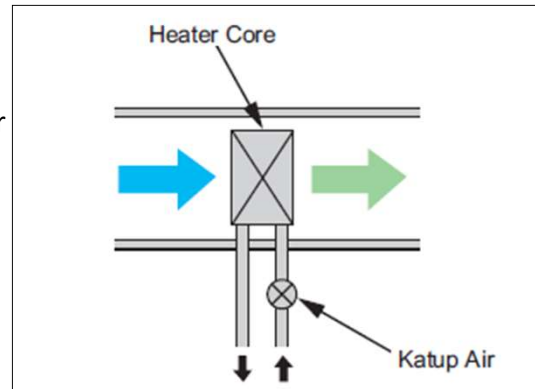

Auto Service Academy

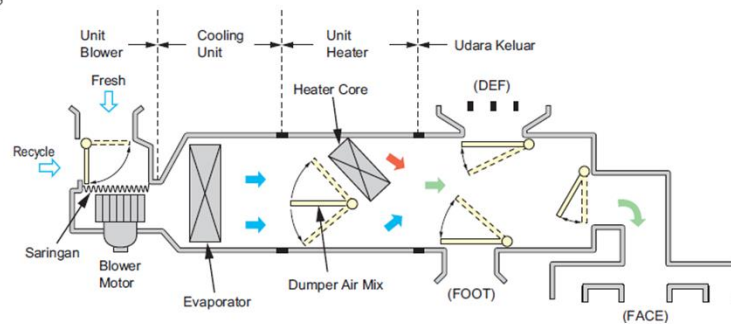
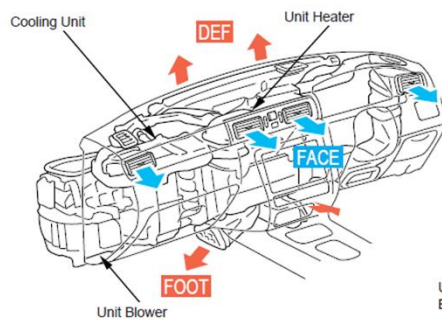

Auto Service Academy



KONSTRUKSI DAN CARA KERJA KOMPONEN UTAMA A/C MOBIL

- Komponen A/C
- Komponen Sirkulasi Pemanas

Auto Service Academy



KOMPONEN AC MOBIL

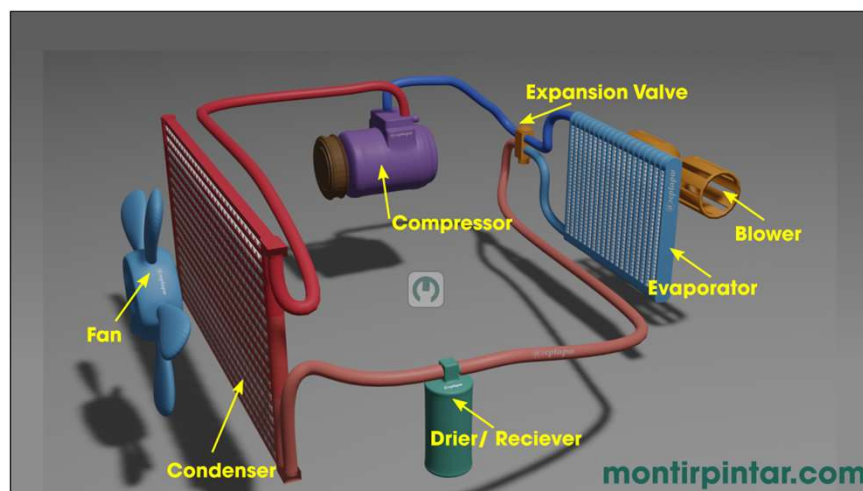

Auto Service Academy



KOMPRESSOR

Fungsi :

Untuk menaikkan tekanan dan suhu refrigerant kemudian disirkulasikan ke kondenser. Kompresor ini digerakkan oleh mesin melalui drive belt



Auto Service Academy



JENIS KOMPRESSOR

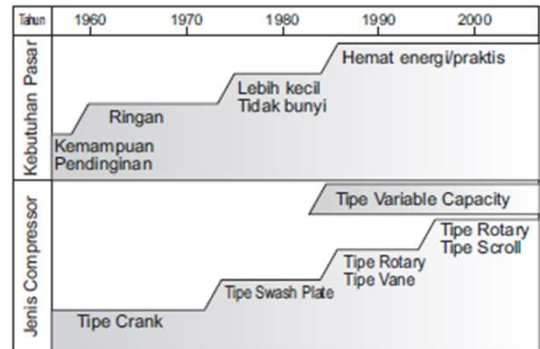
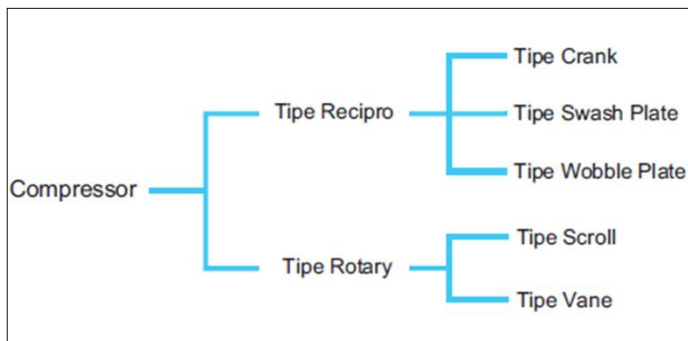

Auto Service Academy



KOMPRESOR TIPE CRANKSHAFT

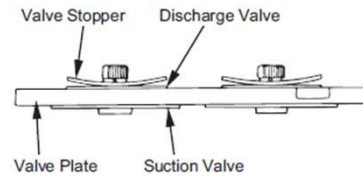
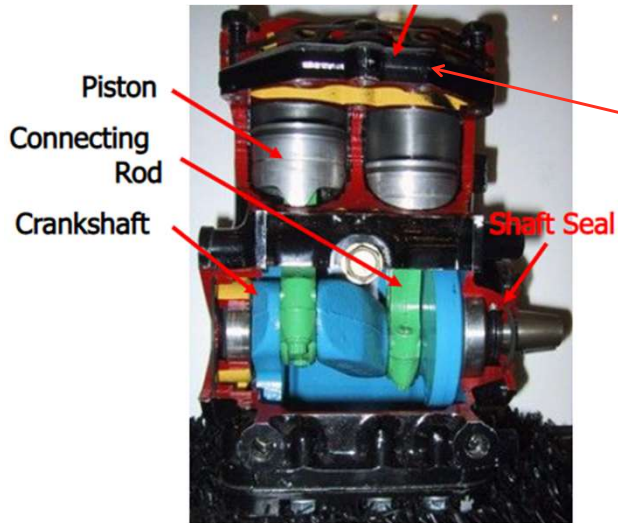

Auto Service Academy



CARA KERJA KOMPRESOR TIPE CRANKSHAFT

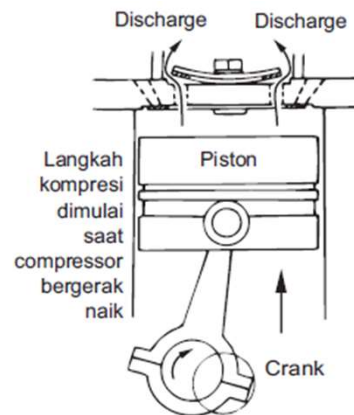
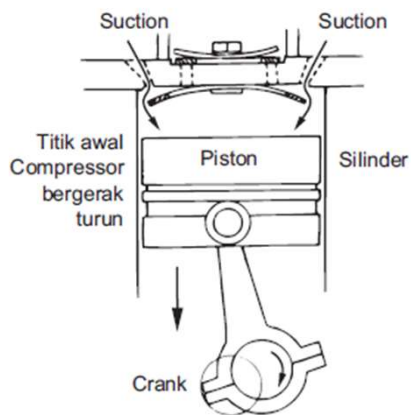

Auto Service Academy



KOMPRESOR TIPE SWASH PLATE

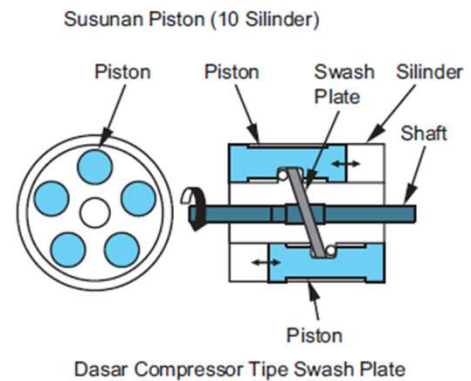
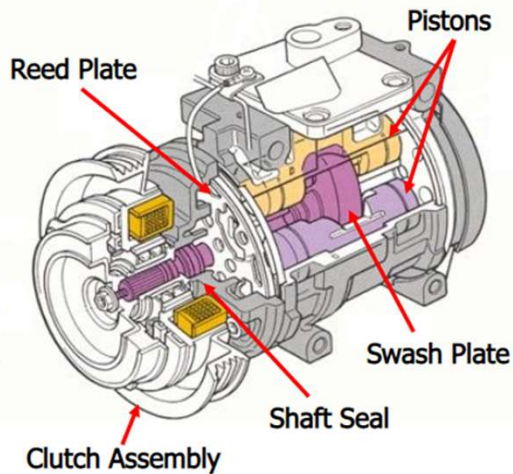

Auto Service Academy



CARA KERJA KOMPRESOR SWASH PLATE

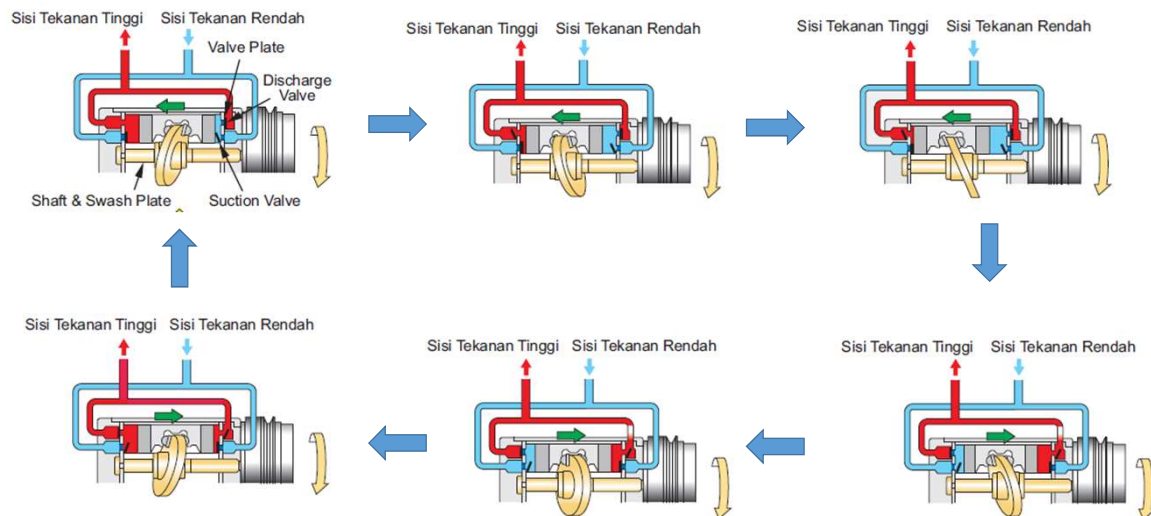

Auto Service Academy



KOMPRESOR TIPE WOBBLE PLATE

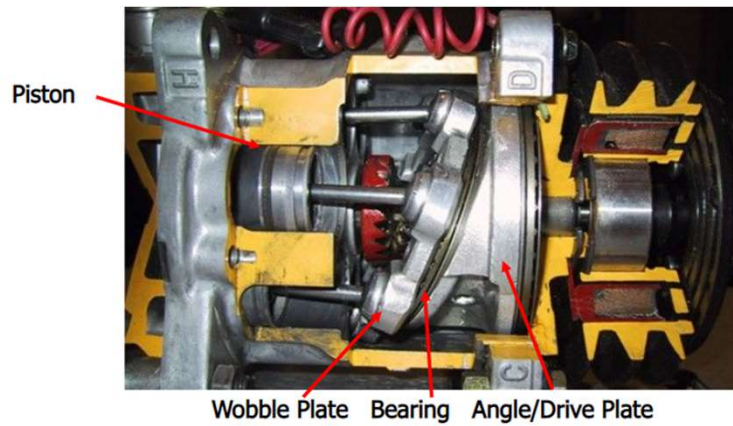

Auto Service Academy



CARA KERJA KOMPRESOR WOBBLE PLATE

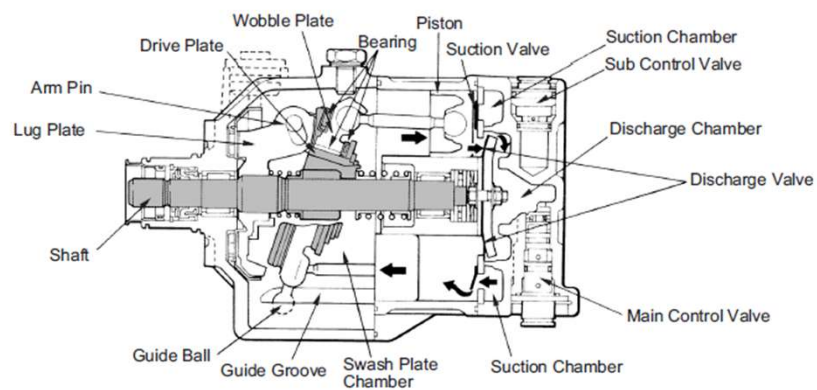

Auto Service Academy



KOMPRESOR TIPE SCROLL

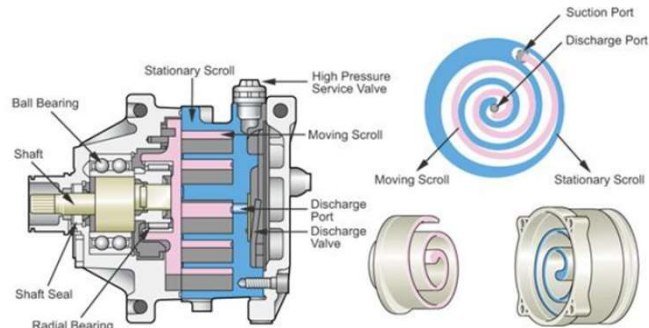

Auto Service Academy

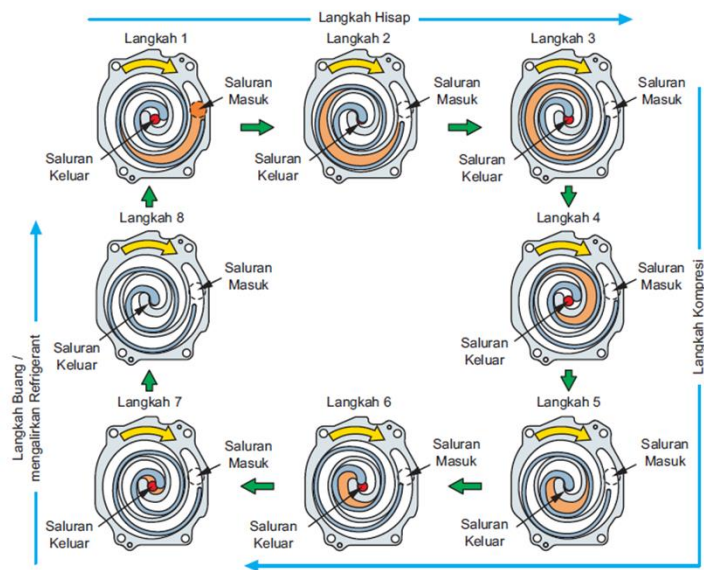

Auto Service Academy



KOMPRESOR TIPE THROUGH VANE

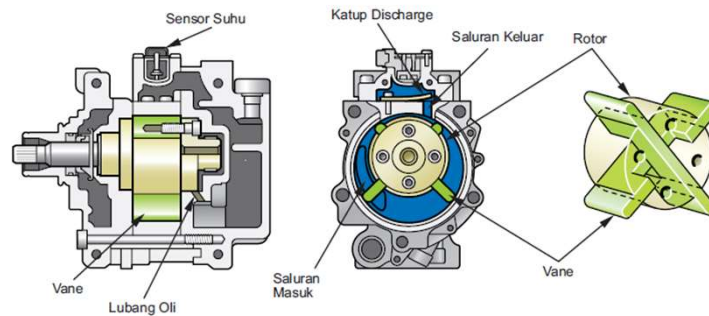

Auto Service Academy

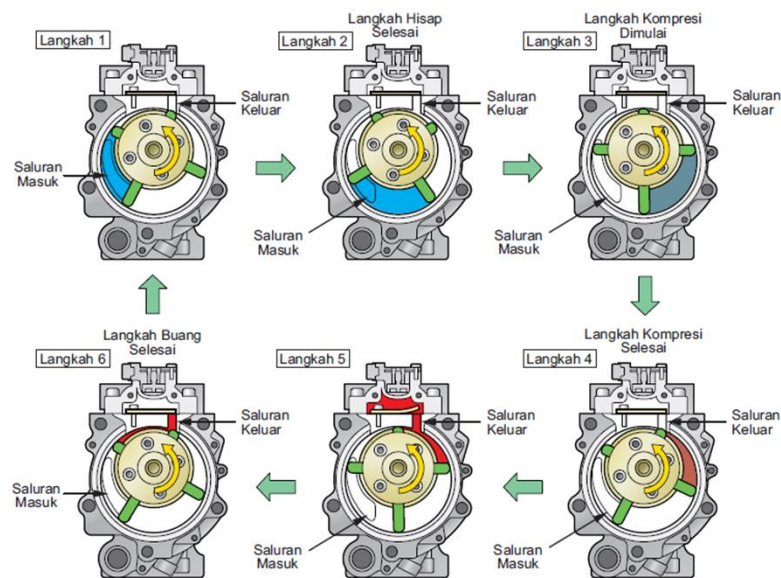

Auto Service Academy



KOMPRESOR TIPE SLIDING VANE

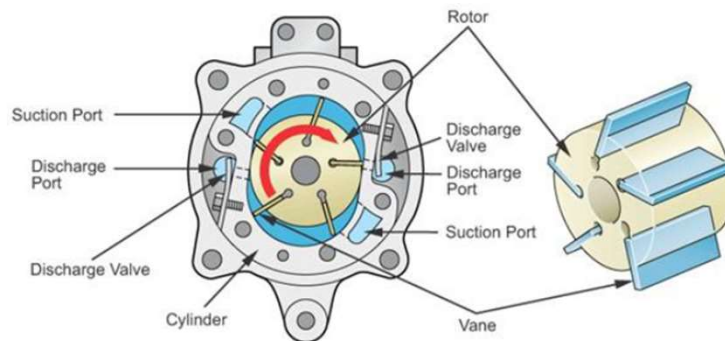

Auto Service Academy



CARA KERJA SLIDING VANE

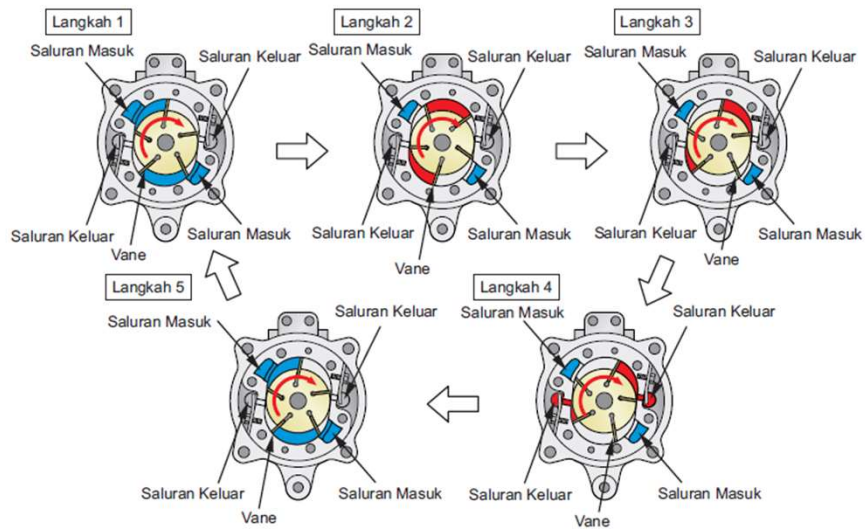

Auto Service Academy



KOMPRESOR TIPE VARIABLE CAPACITY

Tipe variable capacity untuk memenuhi kebutuhan kompresor yang hemat energi dan praktis. Tipe ini menghilangkan kontrol ON/OFF magnetic clutch.

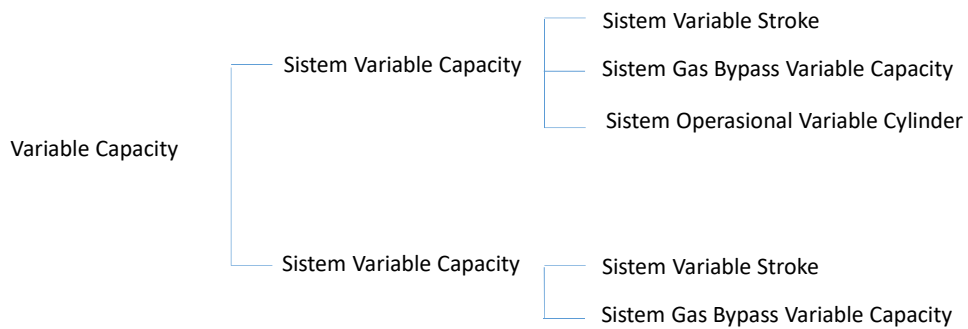

Auto Service Academy



KOMPRESOR TIPE VARIABLE CAPACITY

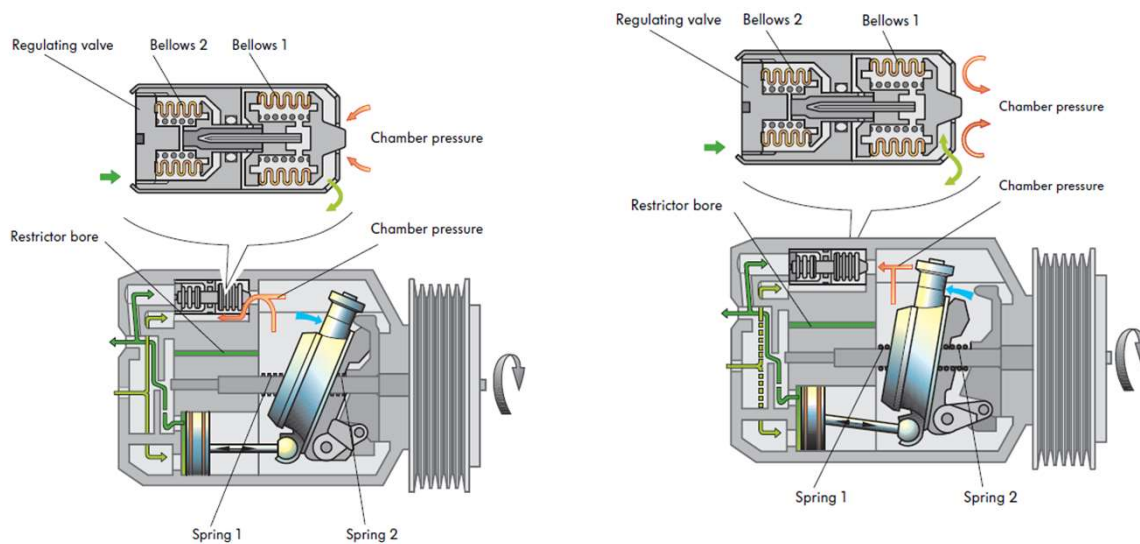

Auto Service Academy



MAGNETIC CLUTCH

Untuk menghubungkan dan memutuskan hubungan ompressor ke mesin.
Prinsip kerjanya adalah dengan mengalirkan arus ke coil.

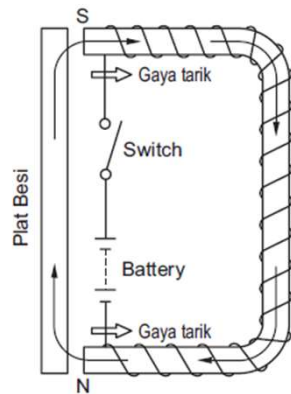

Auto Service Academy



DAMPER & LIMITER

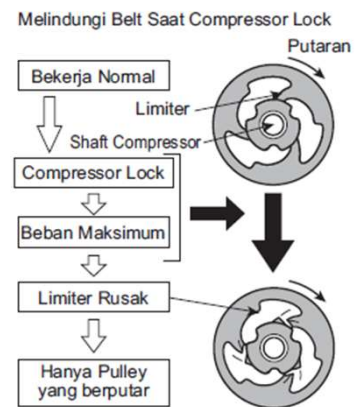
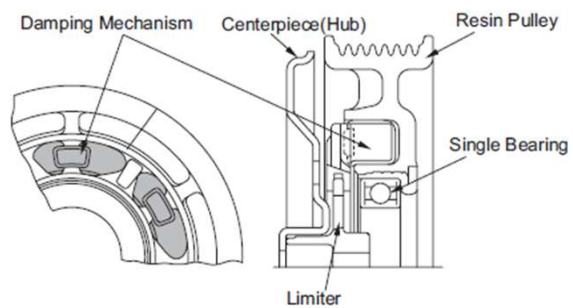

Auto Service Academy



OLI KOMPRESOR

Untuk memberikan pelumasan **bearing kompresor, komponen yang bergesekan** dan bergerak. Oli ini bersirkulasi bersama sama dengan refrigerant. **Jumlah oli harus tepat**, jika oli terlalu banyak atau terlalu sedikit dapat menimbulkan masalah.

Oli kompresor biasa hanya untuk R 12 dan tidak larut pada R 134a sehingga umur compressor menjadi pendek. Untuk R 134a digunakan oli spesial

Auto Service Academy



KONDENSOR

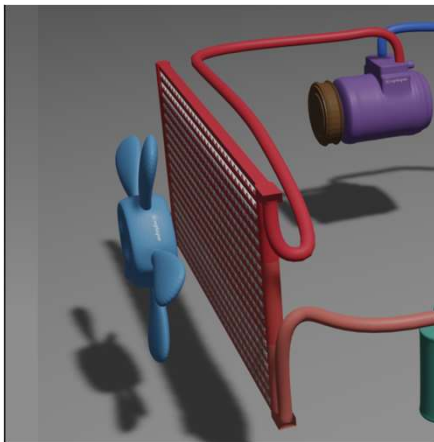

Kondensor adalah tempat pembuangan panas dimana gas refrigerant yang bertekanan tinggi dan bersuhu tinggi didinginkan agar berubah ke bentuk cair. Panas yang terbuang di kondensor sama dengan panas yang diserap oleh evaporator

Auto Service Academy



KONDENSOR

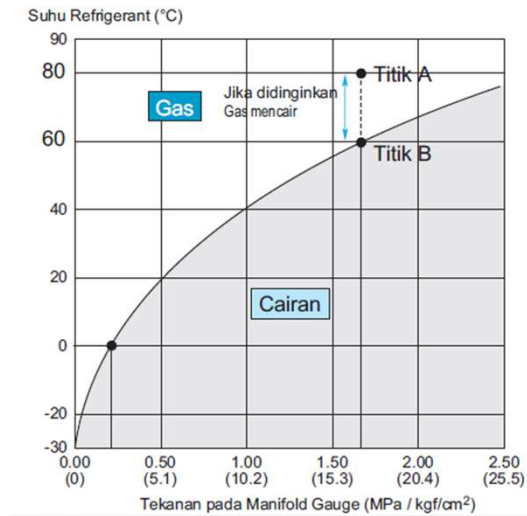

Auto Service Academy



TIPE KONDENSOR

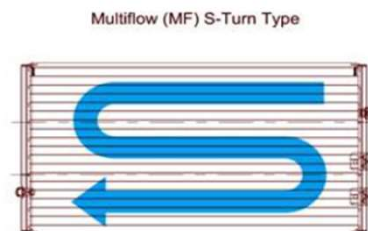
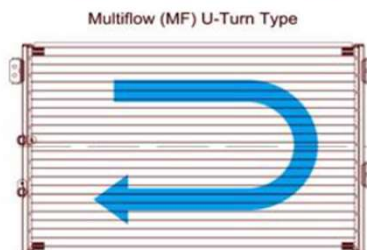
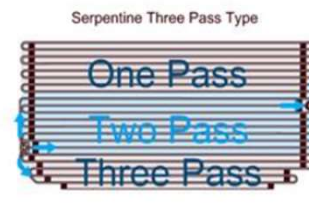
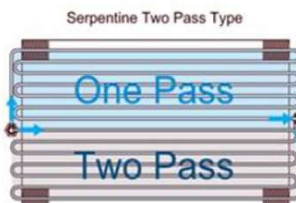
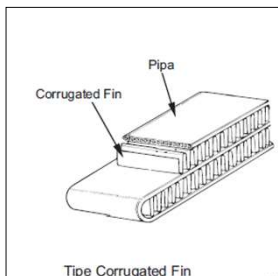
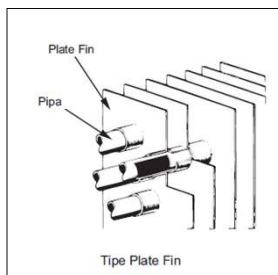

Auto Service Academy



RECIEVER/DRIER

Terdiri dari dryer dan filter. Berfungsi untuk menyerap air dan kotoran yang terdapat di dalam refrigerant.

Pada bagian atasnya terdapat sight glass untuk mengetahui jumlah refrigerant di dalam sistem A/C. Pada model yang lain sight glass dipasang pada pipa diantara receiver dan expansion.

Receiver memisahkan refrigerant dalam bentuk gas dan air oleh perbedaan berat dan mengalirkannya ke expansion dalam bentuk cairan.

Driyer berisi desiccant untuk menyerap uap air

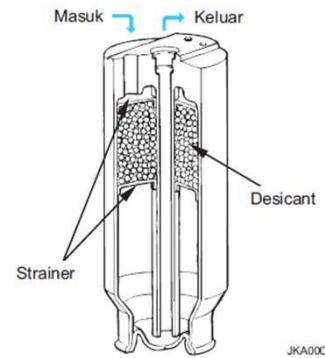

Auto Service Academy



TIPE RECIEVER/DRIER

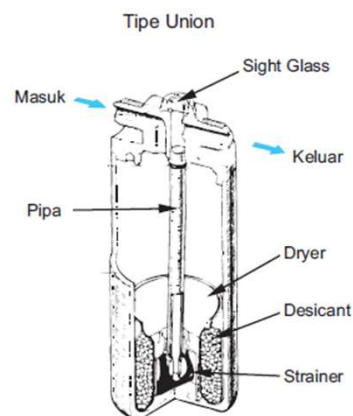
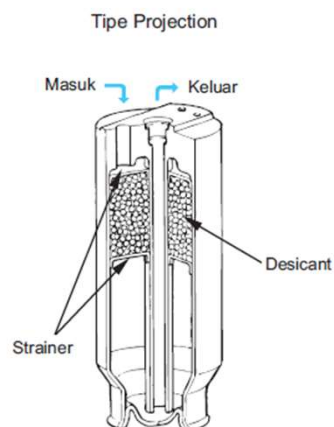

Auto Service Academy



TIPE RECIEVER/DRIER

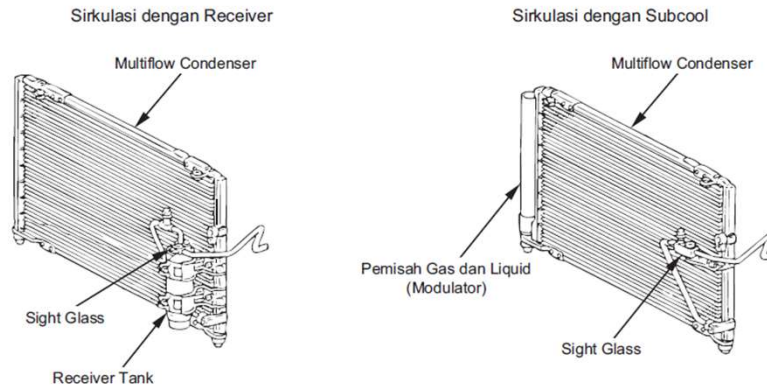

Auto Service Academy



CARA KERJA RECIEVER/DRIER

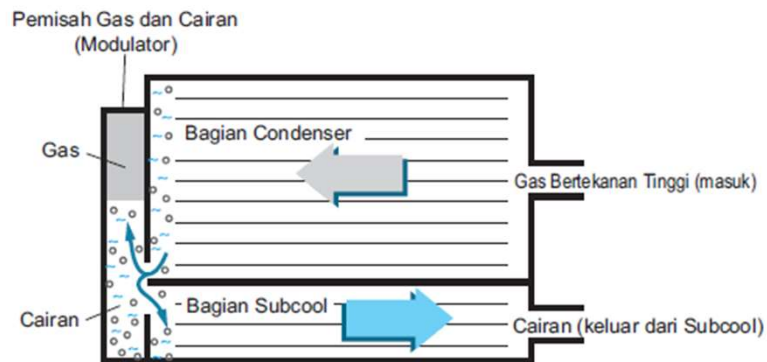

Auto Service Academy



SIGHT GLASS

Sight glass memungkinkan kita memeriksa volume refrigerant dalam sistem. Jika pemasangan sight glass sulit dilihat, sulit/tidak mungkin dipasang diatas receiver, atau jika menggunakan sub cool condensor maka sight glass dipasang terpisah pada pipa.

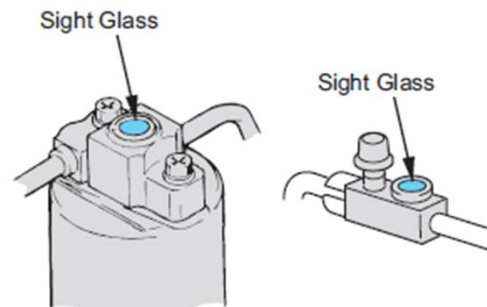

Auto Service Academy



EXPANSION VALVE

Untuk mengatur jumlah aliran refrigerant yang disemprotkan dalam bentuk kabut di evaporator sehingga suhunya dapat diturunkan. Jumlah aliran refrigerant ditentukan oleh naik turunnya valve pada expansion valve.

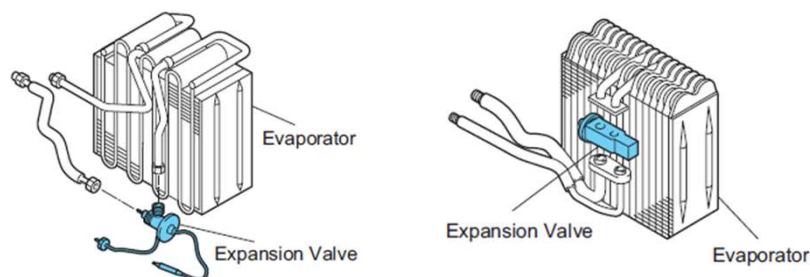

Tipe Joint Connection

Tipe Box

Auto Service Academy



CARA KERJA EXPANSION VALVE

Gas refrigerant juga ada pada diaphragm chamber dan tertutup. Tekanan refrigerant ini akan tinggi jika suhu pipa keluar evaporator tinggi dan sebaliknya. Tekanan pada saluran keluar evaporator diteruskan ke chamber B. Ketika jumlah volume refrigerant yang mengalir sudah cukup, katup tidak bergerak karena tekanan A dan B seimbang antara diaphragm dan tekanan pegas. Jika tekanan chamber A berubah karena perubahan

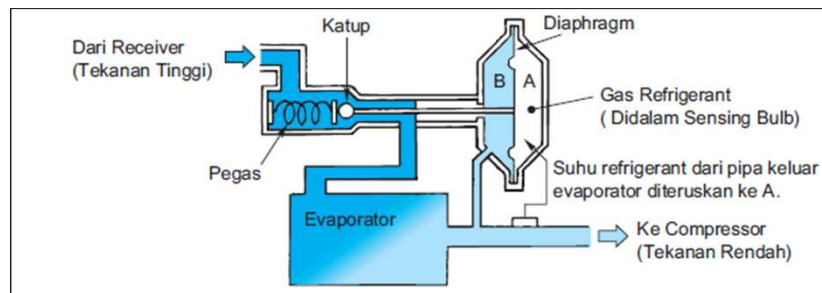

Auto Service Academy



TIPE JOINT CONNECTION

Pada beban pendinginan tinggi (suhu ruangan tinggi) tekanan gas di evaporator tinggi sehingga suhu pada sensing bulb juga tinggi dan menekan valve sampai terbuka lebar, jumlah aliran refrigerant besar.

Saat beban pendinginan rendah, valve akan membuka sedikit, aliran refrigerant kecil

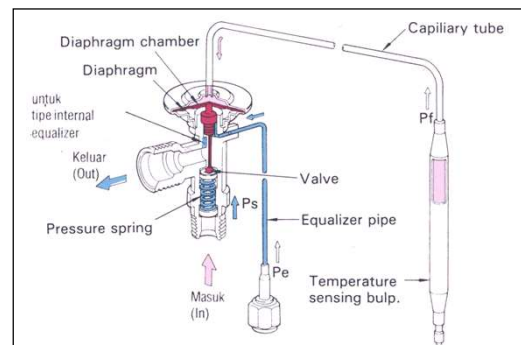

Auto Service Academy



TIPE BOX

Temperature sensing rod mendeteksi suhu refrigerant setelah masuk ke evaporator dan meneruskannya ke bagian atas diaphragm chamber

Karena perubahan suhu dan tekanan gas, temperatur sensing rod bergerak sehingga katup terbuka

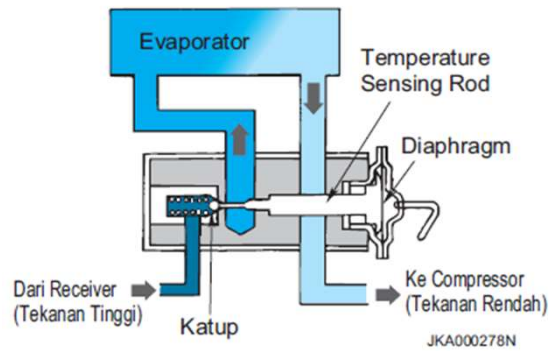

Auto Service Academy



EVAPORATOR

Menguapkan refrigerant dan mengambil panas dari udara sekelilingnya sehingga udara sekelilingnya menjadi dingin.

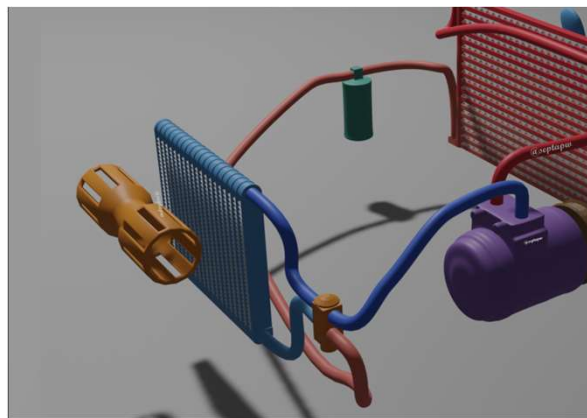

Auto Service Academy



TIPE EVAPORATOR

Tipe-tipe Evaporator

- Tipe Plate Fin
- Tipe Serpentine Fin
- Tipe Drawn Cup

Tipe Plate Fin

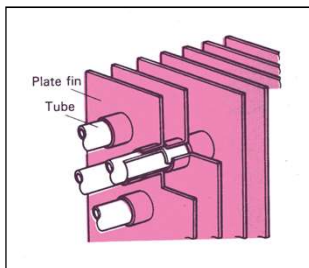

Tipe Serpentine Fin

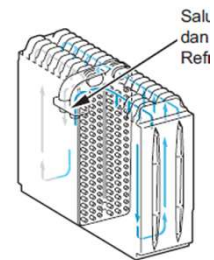
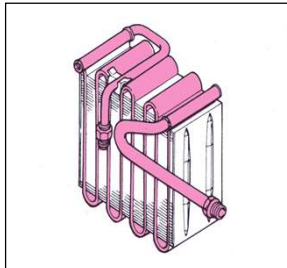

Auto Service Academy



PRESSURE SWITCH

Dipasang diantara receiver drier dan expansion valve untuk mendeteksi ketidaknormalan tekanan didalam sirkulasi dan mematikan magnetic clutch.

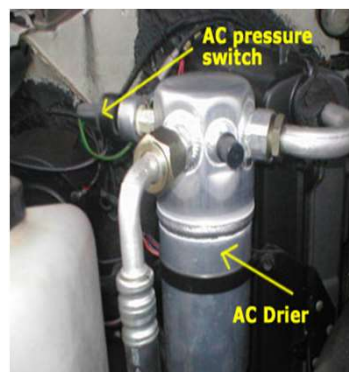

Auto Service Academy



SISTEM KONTROL A/C MOBIL

- Sistem Kontrol Blower
- Sistem Kontrol Compressor
- Sirkuit Elektrikal

Auto Service Academy



SISTEM KONTROL BLOWER

Sistem kontrol blower dilakukan dengan merubah kecepatan motor blower. Pengaturan kecepatan blower dilakukan dengan sistem tahanan (resistor), sistem power transistor dan sistem kontrol blower. Untuk sistem power transistor dan sistem kontrol blower untuk lebih jelasnya lihat buku petunjuk "Automatic A/C".

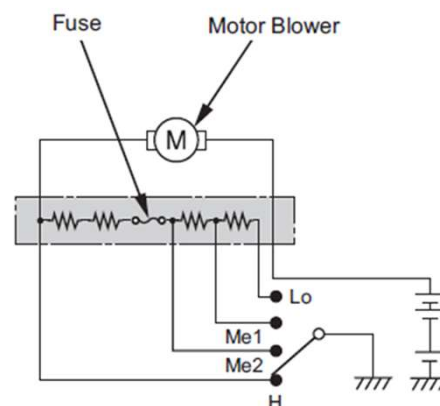

Auto Service Academy



SISTEM KONTROL KOMPRESOR

Sistem kontrol compressor berfungsi untuk (1) mencegah frost, (2) melindungi sirkulasi pendinginan, dan (3) menjaga efisiensi kendaraan

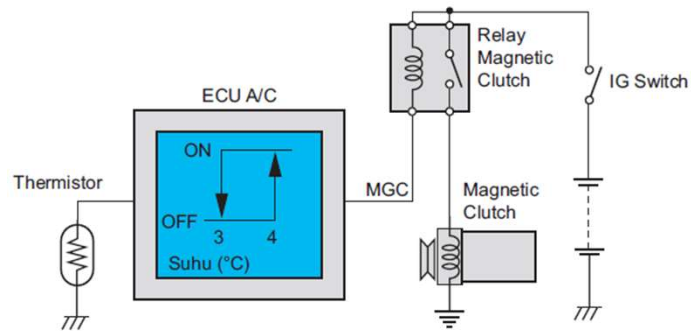

Auto Service Academy



Mencegah Frost (ON-OFF)

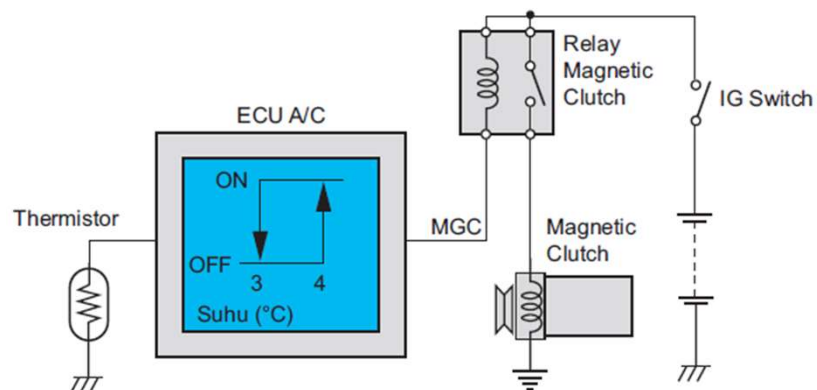

Auto Service Academy



Mencegah Frost - (EPR) Evaporator Pressure Regulator

EPR adalah katup pengatur tekanan yang terpasang diantara compressor dan evaporator. Ketika tekanan refrigerant di evaporator naik sampai 0.18 MPa (1,8 Kg/cm²), tidak akan terjadi frost karena suhu refrigerant akan tetap diatas 0° C.

EPR mengatur jumlah refrigerant yang kembali ke compressor dari evaporator dan mempertahankan tekanan pada evaporator tetap 0.18 MPa (1,8 Kg/cm²), untuk mencegah terjadinya frost pada evaporator

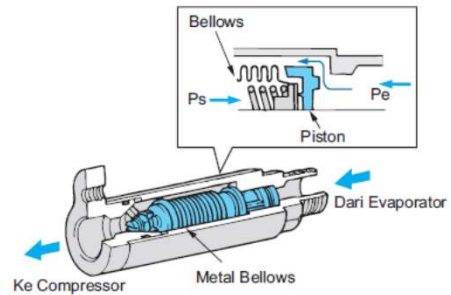

Auto Service Academy



Melindungi Sistem – Pressure Switch

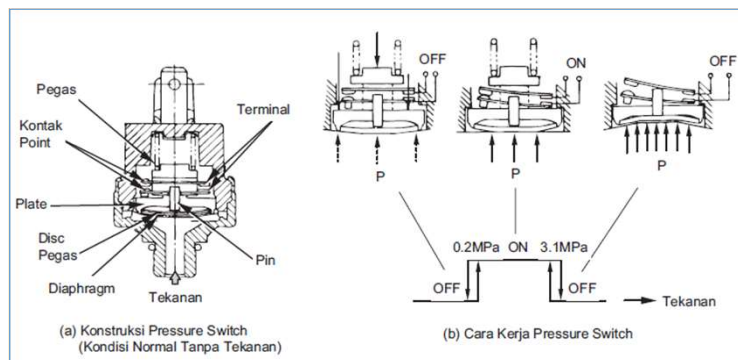
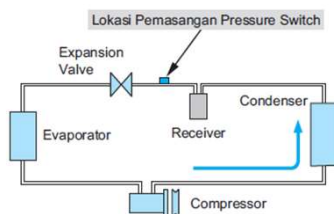

Auto Service Academy



Melindungi Sistem – katup pengaman

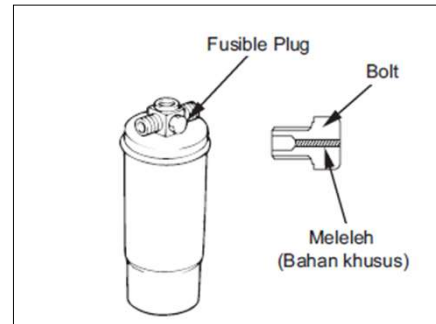

Auto Service Academy



Menjaga Kemampuan/ Unjuk Kerja Mobil

Sistim Kontrol Acceleration Cut

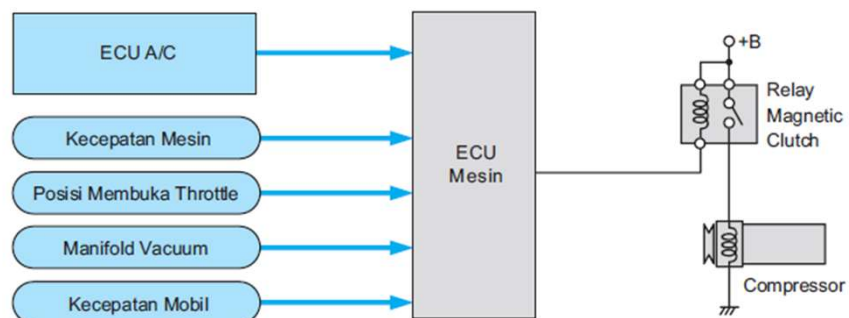

Auto Service Academy



Menjaga Kemampuan/ Unjuk Kerja Mobil

Sistim Kontrol Low Speed Cut

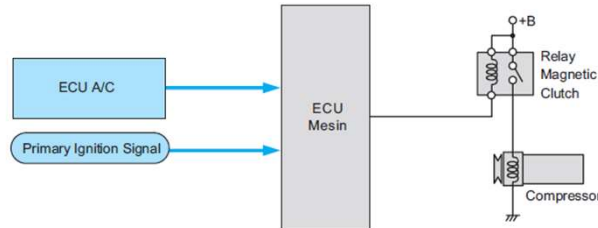

Auto Service Academy



Menjaga Kemampuan/ Unjuk Kerja Mobil

Sistim Kontrol Lock up Cut

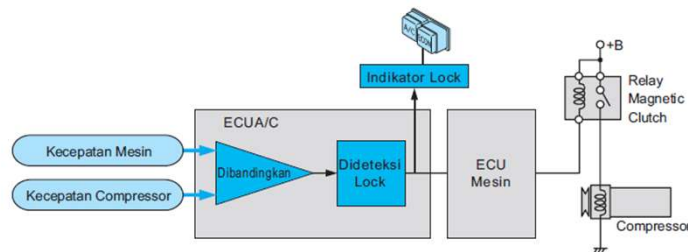

Auto Service Academy



Menjaga Kemampuan/ Unjuk Kerja Mobil

Sistim Electric Fan

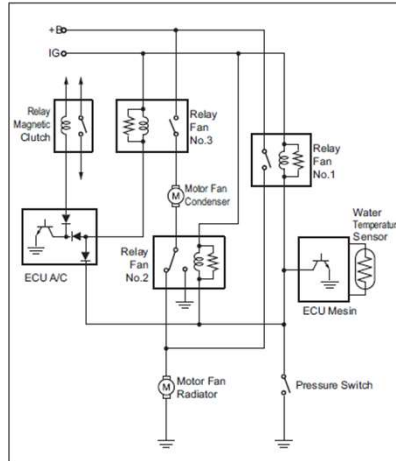
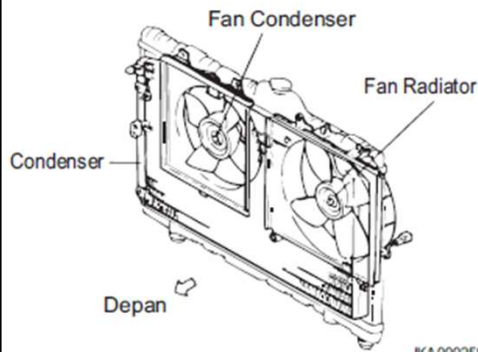

Kontrol

Switch A/C	ON		OFF			
Pressure Switch	ON	OFF	OFF	OFF		
Water Temperature Sensor	ON	OFF	ON	OFF	ON	OFF
Fan Electric	HI	HI	HI	LO	HI	OFF

Auto Service Academy



Sirkuit Dasar A/C Mobil

Sirkuit Dasar A/C Mobil

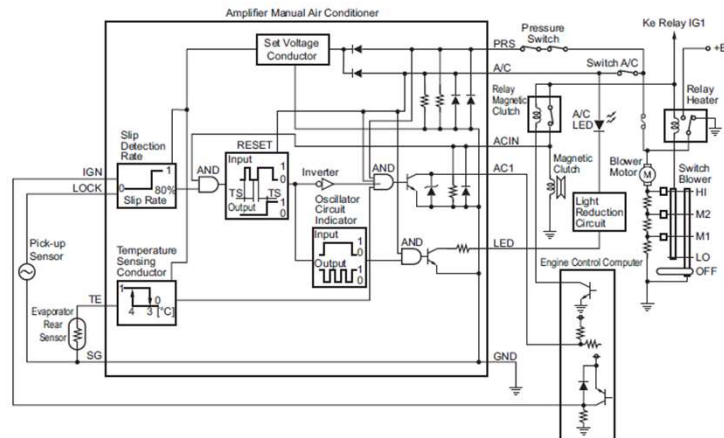

Auto Service Academy

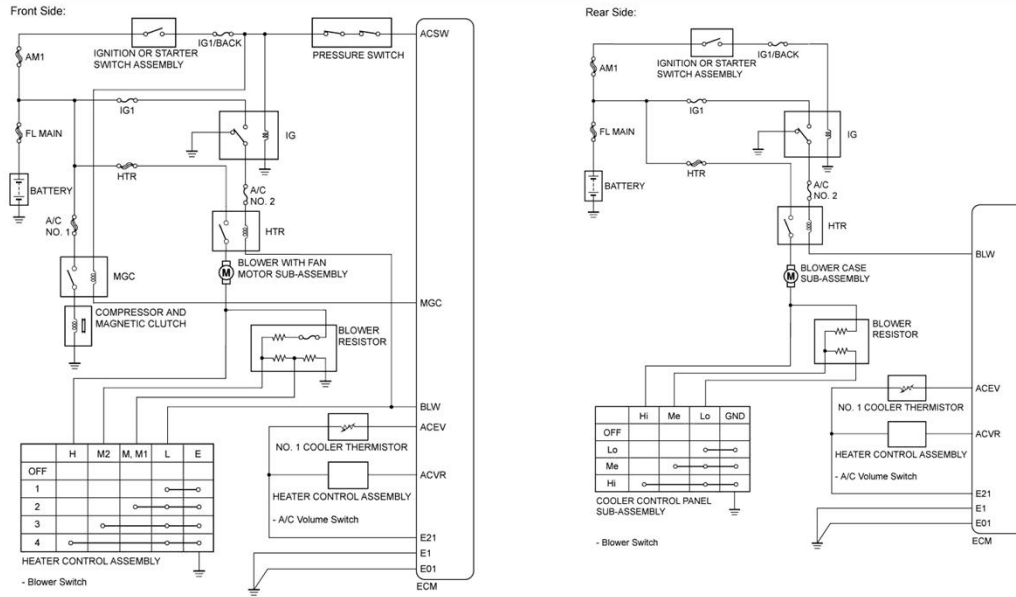

Auto Service Academy



AUTOMATIC CONTROL

Sensors
(for system control and temperature control)

- Sunlight penetration photo sensor G107
- Temperature sensor Dash panel
- Temperature sensor C54
- Blower V42
- Ambient temperature sensor G17
- Temperature sensor Fresh air intake duct temperature sensor C69
- Footwell vent temperature sender C192
- Air conditioner pressure switch F129
- Auxiliary signals:
 - road speed signal
 - engine speed signal
 - time parked signal
- Coolant temperature warning switch (overheating) F14
- Radiator fan thermo switch F38

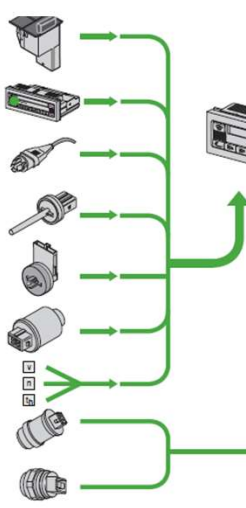

Climatronic control unit Z55 and Air conditioner/Climatronic operating and display unit B7

Diagnosis plug connection T4

Actuators
(for system control and temperature control)

- Footwell motor flap positioning motor V65 with potentiometer G134
- Control flap positioning motor V70 with potentiometer G132
- Temperature flap positioning motor V68 with potentiometer G192
- Air flow flap positioning motor V71 and air recirculation flap with potentiometer G133
- Fresh air blower Control unit Z55 and fresh air blower V2
- Auxiliary signals:
 - engine control unit
 - control unit with display unit in dash panel insert
- Magnetic clud N25
- Radiator fan, right V7 and auxiliary fan V25

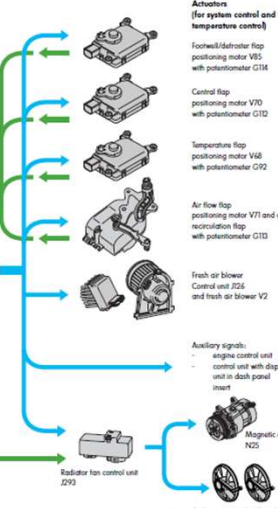

Radiator fan control unit Z93

208_07

Auto Service Academy



SOP PERAWATAN A/C MOBIL

Kondisi pada putaran idle			Kondisi 2000 rpm		
Check	Low	High	Check	Low	High
	Kg/Cm2	Kg/Cm2		Kg/Cm2	Kg/Cm2
	Psi (lbf/in2)	Psi (lbf/in2)		Psi (lbf/in2)	Psi (lbf/in2)

- Periksa jenis freon
- Periksa kerja kompresor
- Periksa bunyi abnormal
- Periksa kebocoran pada selang, pipa, sambungan dan niple tekanan tinggi
- Periksa kebocoran pada selang, pipa, sambungan dan niple tekanan rendah
- Periksa sirip-sirip radiator dan kondensor
- Periksa viscofan
- Periksa semburan angin blower evaporator & temperatur angin yang keluar di blower (filter kotor)
- Periksa fungsi termostat & temperatur evaporator putus C masuk C (diambil rata-rata)
- V-Belt AC, alternator, power steering
- Tensioner belt

Auto Service Academy



PETUNJUK PERBAIKAN A/C MOBIL

- Pemeriksaan Sistem A/C secara Umum
- Periksa apakah HVAC air intake pelunum di bawah winshield tertutup dedaunan.
- Periksa apakah saluran dan selang A/C terlipat atau bengkok
- Periksa apakah ada noda yang mengindikasikan kebocoran pada sambungan pipa
- Periksa kondisi drivebelt.
- Periksa apakah ada dedaunan, kertas atau debu yang menyumbat fin-fin kondensor.
- Periksa kondisi fin kondensor, jika rusak atau bengkok cobalah untuk meluruskannya.
- Hidupkan mesin dan nyalakan sistem A/C, biarkan beberapa menit hingga kerjanya stabil.
- Pastikan heater fan switch bekerja pada semua posisi.
- Pastikan armature plate kompresor A/C berputar pada kecepatan yang sama dengan rotor puli.
- Periksa apakah kipas kondensor dan kipas radiator berputar saat kompresor terhubung dan menghembuskan udara ke ruang mesin.
- Periksa apakah kecepatan idle mesin tetap stabil saat sistem A/C pada Posisi ON atau OFF.

Auto Service Academy



Pembacaan Tekanan saat Normal

Lakukan pengecekan dengan kondisi

- Putaran mesin : 1500 rpm
- Suhu masuk blower : 30-35 °C (86 - 95 °F)
- Kecepatan blower : Hi
- Temperatur kontrol : Maksimum

Referensi

- Tekanan sirkulasi saat AC off :
Hi dan Lo = 5-8 kg/cm²

Petunjuk

Jika EPR pada sistem rusak, masalah tidak dapat diketahui langsung dari tekanan Lo

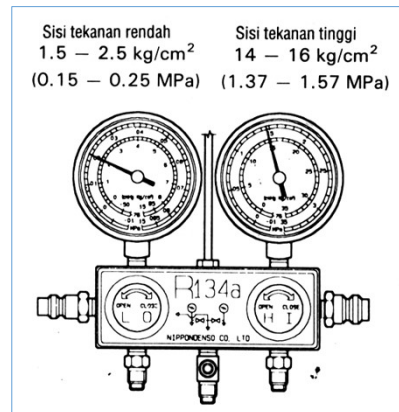

Auto Service Academy



Pembacaan Tekanan saat Kurang

MASALAH	PENYEBAB	TINDAKAN
Tekanan Hi & Lo rendah	Jumlah refrigerant kurang	<ul style="list-style-type: none"> • Cek bocor dan perbaiki • Tambah refrigeranti
Ada gelembung pada sight glass	Ada kebocoran pada sirkulasi	Jika tekanan Hi & Lo mendekati 0, cari kebocoran perbaiki dan isi gas

(Low pressure side) (High pressure side)
 0.5 – 1.0 kg/cm² 7 – 10 kg/cm²
 (0.05 – 0.1 MPa) (0.69 – 0.98 MPa)

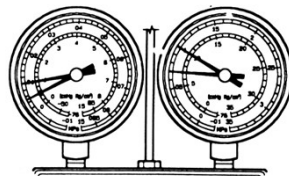

Auto Service Academy



Tekanan AC saat Sirkulasi Tersumbat

MASALAH	PENYEBAB	TINDAKAN
Jika sirkulasi tersumbat sempurna, tekanan Lo di bawah 0 kg/cm ²	Sirkulasi tersumbat	<ul style="list-style-type: none"> Periksa receiver, ex valve, EPR, dll Ada perbedaan suhu In dan Out yang tersumbat Lakukan pemvacuman setelah memperbaiki kerusakan
Jika sirkulasi tersumbat sebagian, tekanan Lo akan rendah		

Sisi tekanan rendah Vacuum
Sisi tekanan tinggi 5 – 6 kg/cm²
(0.5 – 0.6 MPa)

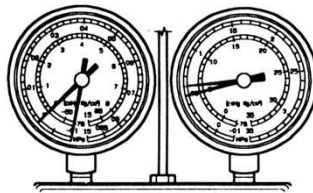

Auto Service Academy



Tekanan AC saat ada Air Dalam Sirkulasi

MASALAH	PENYEBAB	TINDAKAN
Saat AC mulai ON, kerja AC normal kemudian vacum atau tekanan Lo rendah	Expansion valve tersumbat bunga es	<ul style="list-style-type: none"> Periksa ex valve Ganti receiver dryer Lakukan pemvacuman setelah memperbaiki kerusakan

Sisi tekanan rendah
Ketika abnormal 1.5 – 2.5 kg/cm²
(0.15 – 0.25 MPa)
Ketika normal 14 – 16 kg/cm²
(1.37 – 1.57 MPa)
Sisi tekanan tinggi 7 – 10 kg/cm²
(0.69 – 0.98 MPa)

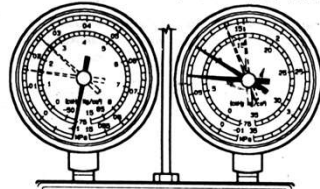

Auto Service Academy



Tekanan AC saat Kompresi Jelek

MASALAH	PENYEBAB	TINDAKAN
Tekanan Lo : tinggi, Hi : rendah Jika AC dimatikan dengan cepat tekanan Lo & Hi menjadi sama	Compressor rusak	<ul style="list-style-type: none">Periksa kompresorJika kompresor disentuh tidak panas, fungsi kompresor jelek

Sisi tekanan rendah Sisi tekanan tinggi
4 – 6 kg/cm² 7 – 10 kg/cm²
(0.4 – 0.6 MPa) (0.69 – 0.98 MPa)

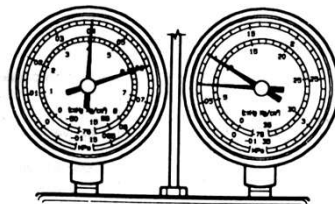

Auto Service Academy



Tekanan AC saat Refrigerant Terlalu Banyak

MASALAH	PENYEBAB	TINDAKAN
1. Tekanan Lo & Hi terlalu tinggi	Refrigerant terlalu banyak	<ul style="list-style-type: none">Periksa jumlah refrigerant
2. Pada sight glass tidak terlihat gelembung 3. AC kurang dingin	Pendinginan kondensotr jelek	<ul style="list-style-type: none">Buang sedikit refrigerant kalau terlalu banyakPeriksa pendingin pada kendaraan (fan, water thermostat, radiator,dll)

Sisi tekanan rendah Sisi tekanan tinggi
2.5 – 3.5 kg/cm² 20 – 25 kg/cm²
(0.25 – 0.35 MPa) (1.96 – 2.45 MPa)

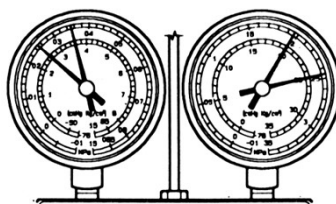

Auto Service Academy



Tekanan AC saat Sirkulasi Kemasukan Udara

MASALAH	PENYEBAB
1. Tekanan Lo& Hi terlalu tinggi 2. Pipa tekanan rendah panas 3. Ada gelembung pada sight glass	Ada air dalam sirkulasi

Sisi tekanan rendah Sisi tekanan tinggi
2.5 – 3.0 kg/cm² 20 – 25 kg/cm²
(0.25 – 0.30 MPa) (1.96 – 2.45 MPa)

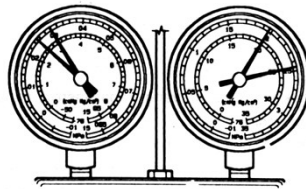

Auto Service Academy



Tekanan AC saat Katup Ekspansi Membuka Terlalu Lebar

MASALAH	PENYEBAB	TINDAKAN
1. Tekanan Lo& Hi terlalu tinggi 2. Ada air pada pipa suction	Expansion valve salah pasang atau rusak	<ul style="list-style-type: none">• Cek expansion valve• Cek pemasangan sensor panas pada ex valve• Biasanya terjadi setelah ganti ex valve

Sisi tekanan rendah Sisi tekanan tinggi
2.5 – 3.5 kg/cm² 20 – 25 kg/cm²
(0.25 – 0.35 MPa) (1.96 – 2.45 MPa)

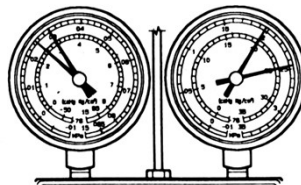

Auto Service Academy